

VBSS19

V-BELT DRIVEN LIVE ROLLER STRAIGHT SPURS (1.9 in. dia. x 16 ga. rollers)

The Model VBSS19 straight spurs are used to transfer product from one conveying line onto another. Suitable for merging or diverging applications, they are available self-powered or can be slave driven from a straight section or curve.



- 12 Widths
- 30 and 45 degree straight spurs
- Right or Left Hand Units Available

BETWEEN FRAME WIDTH	OVERALL FRAME WIDTH	"A"		"B"		WEIGHT (LBS.)	
		30°	45°	30°	45°	30°	45°
13"	16"	38"	29"	36"	27"	202	176
15"	18"	41"	32"	39"	30"	210	179
17"	20"	47"	35"	45"	33"	214	182
19"	22"	50"	38"	48"	36"	216	185
21"	24"	53"	41"	51"	39"	219	188
23"	26"	56"	44"	54"	42"	222	191
25"	28"	62"	47"	60"	45"	224	194
27"	30"	65"	50"	63"	48"	227	198
31"	34"	74"	56"	72"	54"	230	201
33"	36"	77"	59"	75"	57"	235	208
37"	40"	86"	65"	84"	63"	239	212
39"	42"	89"	68"	87"	66"	243	216

*T= Tapered, S- Straight

PLAN VIEW - 30°, 45° STRAIGHT SPURS

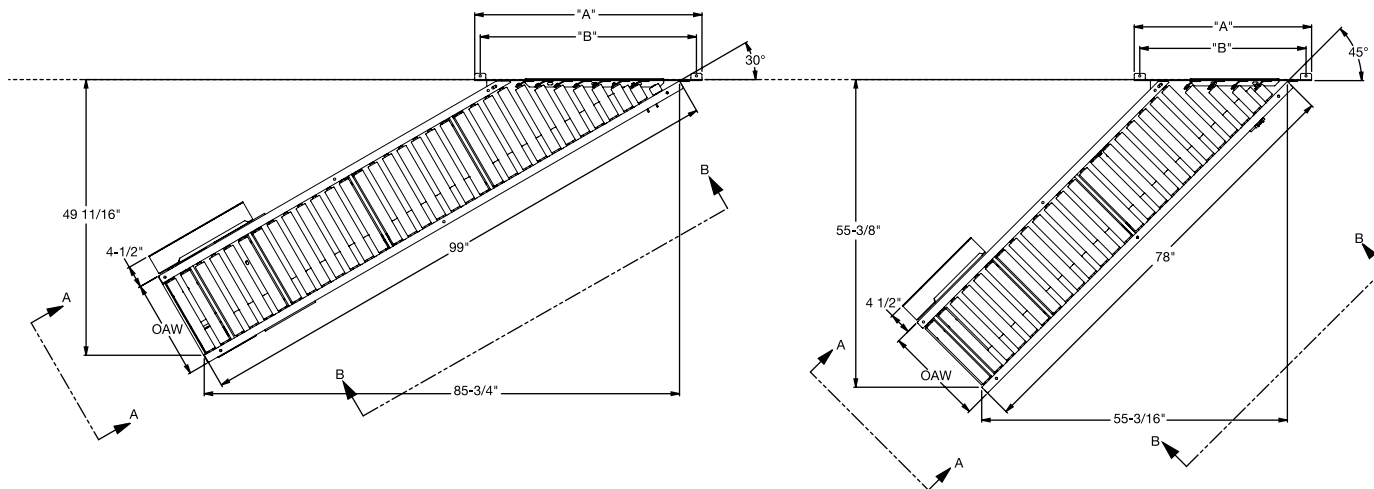

SECTION VIEW A-A

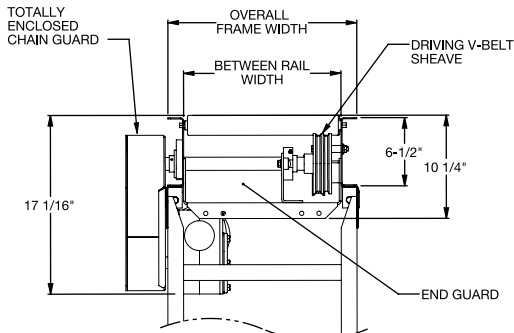

SIDE VIEW B-B

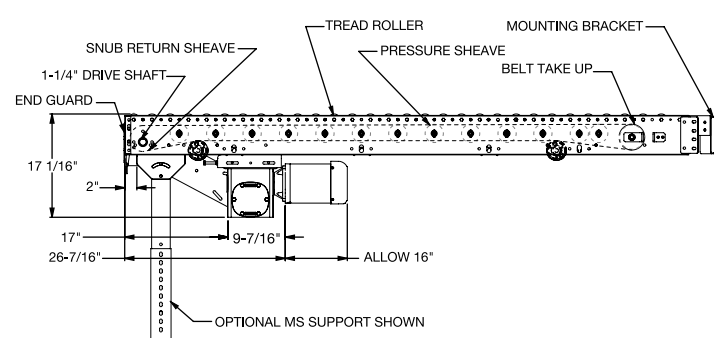

Note: Curve spurs are non-accumulating

STANDARD SPECIFICATIONS

BED – 6 1/2 in. deep x 1 1/2 in. flange x 12 ga. powder coated steel channel with 1.9 in. dia. x 16 ga. galvanized tread rollers spaced every 3 in.

STRAIGHT SPUR: 30 and 45 degree straight spurs.

COUPLINGS – Butt type for connecting to VBS19, VBC19, BDS19T or BDS19M conveyors.

END DRIVE – Mounted underneath bed section of short rail

DRIVE BELT – Endless B-section V-belt, industrial grade.

POSITIVE DRIVE PRESSURE SHEAVES – 2 1/2 in. dia. with 3/8 in. bore.

SNUB RETURN SHEAVE – 4 in. dia. x 5/8 in. bore V type and/or 4 5/8 in. dia. x 5/8 in. bore flat type.

TAKE-UP – Take-ups provided to maintain proper V-belt tension.

BEARINGS – Tread rollers have pre-lubricated ball bearings. Flange and pillow block bearings are sealed and pre-lubricated.

MOUNTING BRACKET – Bracket is supplied to attach spur to side channels of a VBS19, BDS19T or BDS19M conveyors.

CONVEYING SPEED – Constant 65 FPM.

SPEED REDUCTION – Sealed worm gear speed reducer with No. 50 chain to drive shaft.

MOTOR – 1/2 HP – 230/460V-3 phase 60Hz. totally enclosed fan cooled, energy efficient.

CAPACITY – 500 lbs. total distributed live load.

Live roller spurs are used to transfer product onto and off of main conveyor lines. The illustrations below show the correct usage of turning wheels and plow arms with spurs in diverging and merging applications

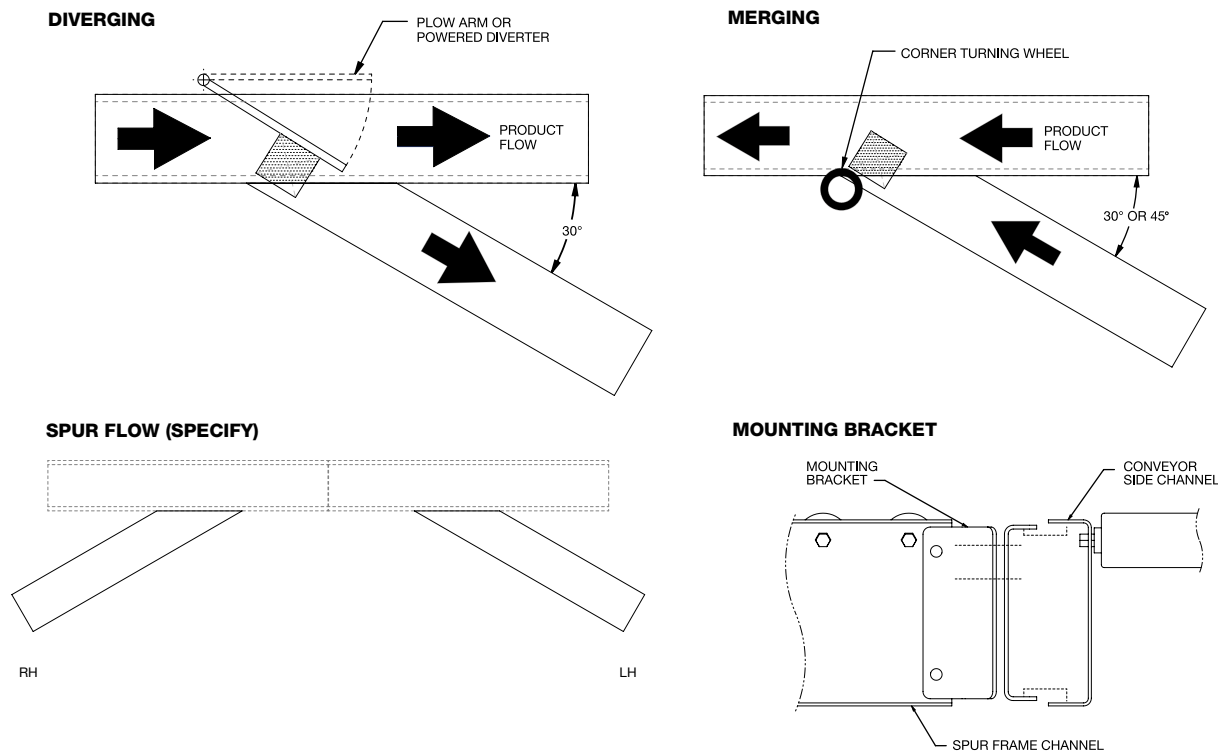

OPTIONAL EQUIPMENT

FLOOR SUPPORTS – SMS Type floor supports are available with a wide range of adjustments. Specify top of roller elevation. One support is required at every bed joint and at the ends of conveyor. Holes in feet are provided for lagging to floor. Knee braces supplied on SMS-7 support and above.

BED LENGTHS – 57 in., 63 in., 69 in., 75 in., 81 in., and 87 in. Drive not available on all lengths and widths. Contact factory

CONVEYING SPEED – Other constant and variable speeds. Note: Capacity affected with speed change.

- Underhung and side mounted drives: 25 – 120 FPM in any increment
- Shaft mounted drive: 25, 30, 45, 50, 65, 85, and 105 FPM nominal
- Consult factory for speeds not listed

SHAFT MOUNTED DRIVE – Motor reducer unit mounted on extended drive shaft. Mounting bracket and torque arm allow for multiple mounting positions. Minimum elevation:

- Standard sheave retainer: 10 1/4 in. TOR
- Low elevation sheave retainer: 8 3/4 in. TOR

SIDE MOUNTED DRIVE – Motor reducer unit mounted to side of conveyor. Minimum elevation:

- Standard sheave retainer: 10 1/4 in. TOR
- Low elevation sheave retainer: 9 1/2 in. TOR

GUIDE RAILS – Adjustable channel guide rails, fixed angle and channel guide rails. Note: If product comes in contact with guard rails, product flow will be affected.

OTHER ACCESSORIES – Poly-tier supports, ceiling hangars. See accessory section.

SLAVE DRIVEN – Omit standard drive and slave drive straight spur from VBS19, VBC19, BSD19M or BSD19T conveyors. Minimum elevation 11 in. (Provide sketch illustrating location of slave connection).

MOTORS – Inverter duty, premium energy efficient, single phase, brake motor, other characteristics. 1 HP maximum.

ELECTRICAL CONTROLS – One direction manual start switch, reversing drum switch, non-reversing or reversible IEC starters and push-button stations, AC variable frequency drive.