

VBCS19

V-BELT DRIVEN LIVE ROLLER CURVE SPUR (1.9 in. dia. x 16 ga. rollers)

The Model VBCS19 curve spurs are used to transfer product from one conveying line onto another. Suitable for merging or diverging applications, they are available self-powered or can be slave driven from a straight section or curve.



- 12 Widths
- 30 and 45 degree curve spurs
- Right or Left Hand Units Available

BETWEEN FRAME WIDTH	OVERALL FRAME WIDTH	"R"	"A"		"B"		"C"		"D"		"E"		TOTAL NUMBER OF ROLLERS *		WEIGHT (LBS.)	
			30°	45°	30°	45°	30°	45°	60°	90°	30°	45°	30°	45°	30°	45°
13"	16"	24"	38"	29"	36"	27"	30"	21"	38"	21-7/8"	42-1/4"	50"	12S/10T	13S/8T	206	195
15"	18"	32-1/2"	41"	32"	39"	30"	54"	36"	63"	35"	61-5/8"	66-5/8"	20S/14T	18S/10T	245	224
17"	20"		47"	35"	45"	33"									255	233
19"	22"		50"	38"	48"	36"									264	241
21"	24"		53"	41"	51"	39"									270	250
23"	26"	56"	44"	54"	42"	287	262									
25"	28"	62"	47"	60"	45"	299	276									
27"	30"	65"	50"	63"	48"	311	282									
31"	34"	48"	74"	56"	72"	54"	75"	48"	89"	48"	58-1/2"	86-1/16"	27S/22T	22S/14T	380	322
33"	36"		77"	59"	75"	57"									390	329
37"	40"		86"	65"	84"	63"									406	340
39"	42"		89"	68"	87"	66"									416	351

*T= Tapered, S- Straight

PLAN VIEW - 30°, 45° CURVE SPURS

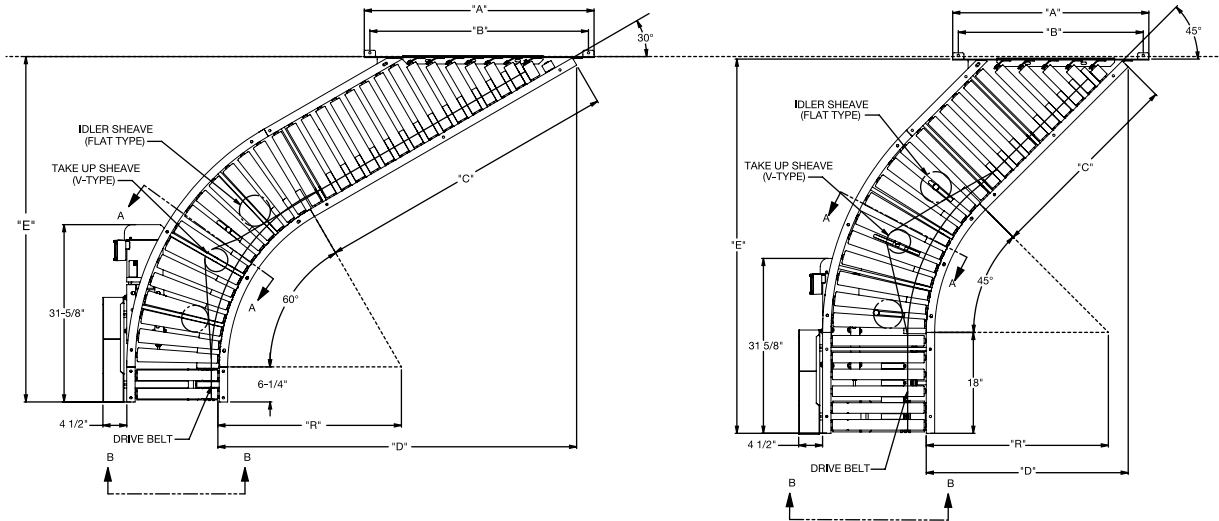

END/SIDE VIEW

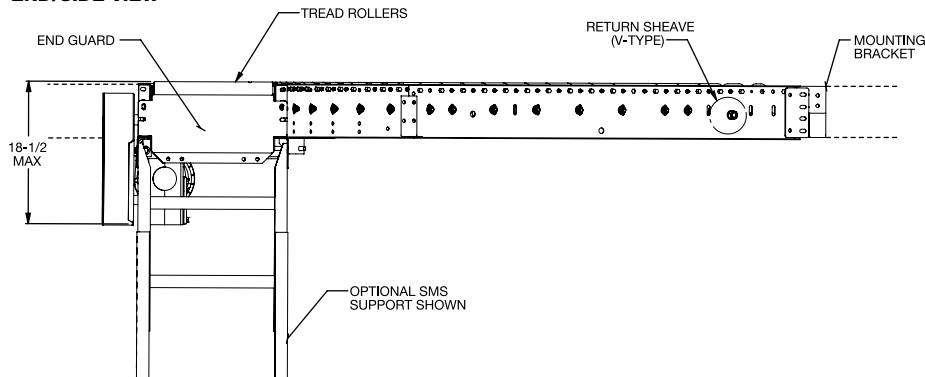

SECTION VIEW A-A

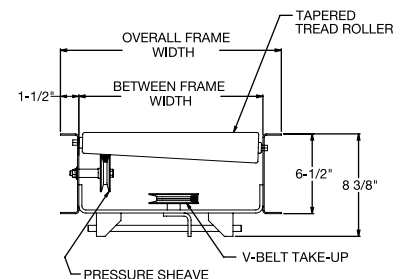

Note: Curve spurs are non-accumulating

STANDARD SPECIFICATIONS

BED – 6 1/2 in. deep x 1 1/2 in. flange x 12 ga. powder coated steel channel with 2-1/2 in. dia. tapered to 1-11/16 in. dia. x 14 ga. galvanized rollers. 1.9 in. dia. x 16 ga. galvanized rollers provided in tangent sections.

SPUR CURVES: 30 and 45 degree spur curves. 24 in, 32 1/2 in. or 48 in. radius dependent upon between frame widths.

COUPLINGS – Butt type for connecting to VBS19, VBC19, BDS19T or BDS19M conveyors.

END DRIVE – Mounted underneath bed section on outside radius.

DRIVE BELT – Endless B-section V-belt, industrial grade.

POSITIVE DRIVE PRESSURE SHEAVES – 2 1/2 in. dia. with 3/8 in. bore.

IDLER SHEAVE – 4 in. dia. x 5/8 in. bore V-type and/or 5 in. dia. 5/8 in. bore flat-type.

Live roller spurs are used to transfer product onto and off of main conveyor lines. The illustrations below show the correct usage of turning wheels and plow arms with spurs in diverging and merging applications

TAKE-UP SHEAVE – 4 3/8 in. dia. x 5/8 in. bore V-type sheave to maintain proper V-belt tension.

BEARINGS – Tread rollers have pre-lubricated ball bearings. Flange and pillow block bearings are sealed and pre-lubricated.

MOUNTING BRACKET – Bracket is supplied to attach spur to side channel of a VBS19, BDS19T or BDS19M conveyors.

CONVEYING SPEED – Constant 65 FPM.

SPEED REDUCTION – Sealed worm gear speed reducer with No. 50 roller chain to drive shaft.

MOTOR – 1/2 HP –230/460V-3 phase 60Hz totally enclosed fan cooled, energy efficient

CAPACITY – 500 lbs. total distributed live load.

DIVERGING

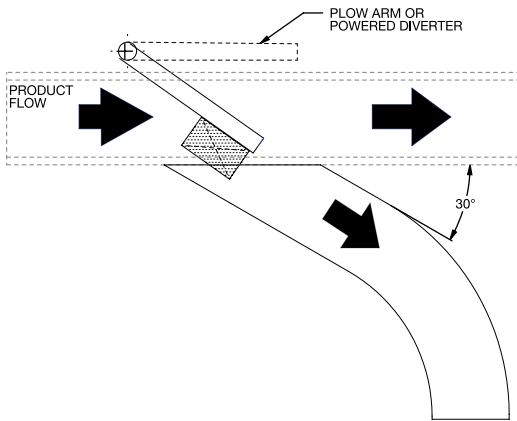

MERGING

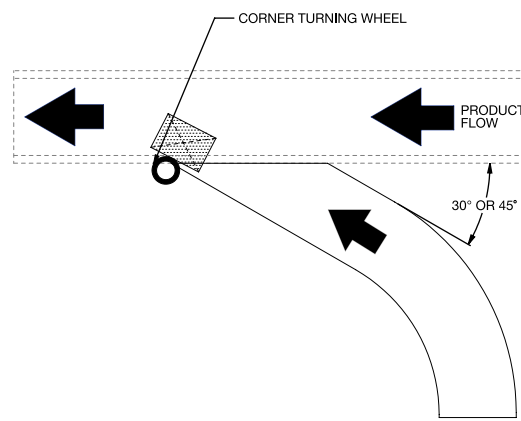

SPUR FLOW (SPECIFY)

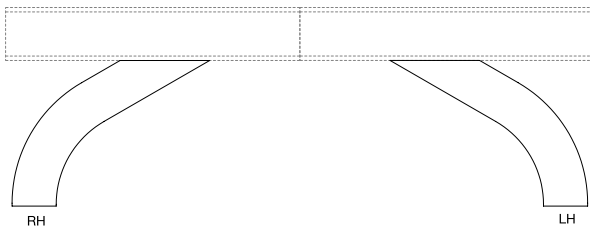

MOUNTING BRACKET

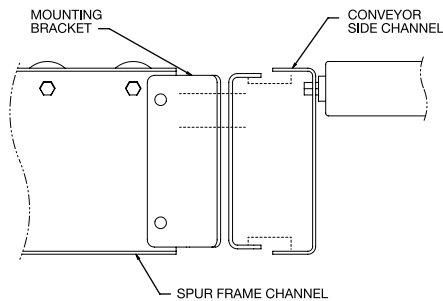

OPTIONAL EQUIPMENT

FLOOR SUPPORTS – SMS Type floor supports are available with a wide range of adjustments. Specify top of roller elevation. One support is required at every bed joint and at the ends of conveyor. Holes in feet are provided for lagging to floor. Knee braces supplied on SMS-7 support and above.

CONVEYING SPEED – Other constant and variable speeds.

Note: Capacity affected with speed change.

- Underhung and side mounted drives: 25 – 120 FPM in any increment
- Shaft mounted drive: 25, 30, 45, 50, 65, 85, and 105 FPM nominal
- Consult factory for speeds not listed

END DRIVE – Mounted on inside radius. Minimum elevation 18-7/8 in. TOR.

SHAFT MOUNTED DRIVE – Drive unit mounted on extended drive shaft. Mounting bracket and torque arm allow for multiple mounting positions. Minimum elevation:

- Standard sheave retainer: 10 1/4 in TOR
- Low elevation sheave retainer: 8 3/4 in. TOR

SIDE MOUNTED DRIVE – Motor reducer unit mounted to side of conveyor. Minimum elevation:

- Standard sheave retainer: 10 1/4 in. TOR
- Low elevation sheave retainer: 9 1/2 in. TOR

GUIDE RAILS – Adjustable channel guide rails, fixed angle and channel guide rails. Note: If product comes in contact with guide rails, product flow will be affected.

OTHER ACCESSORIES – Poly-tier supports, ceiling hangars. See accessory section.

SLAVE DRIVEN – Omit standard drive and slave drive curve spur from VBS19, VBC19, BDS19M, or BDS19T conveyors. Minimum elevation 11 in. (Provide sketch illustrating location of slave connection).

MOTORS – Inverter duty, premium energy efficient, single phase, brake motor, other characteristics. 1 HP maximum.

ELECTRICAL CONTROLS – One direction manual start switch, reversing drum switch, non-reversing or reversible IEC starters and push-button stations, AC variable frequency drive.