

VBC19

V-BELT DRIVEN LIVE ROLLER CURVE (1.9 in. dia. x 16 ga. rollers)

The VBC19 live roller curves are compatible with straight sections and spurs providing flexibility to your conveyor line. They are available self-powered or can be slave driven from a straight section or spur.



- 12 Widths
- Reversible
- Tapered Tread Rollers
- 30, 45, 60 and 90 degree curves

BETWEEN FRAME WIDTH	OVERALL FRAME WIDTH	"R"	TOTAL NUMBER OF ROLLERS *				WEIGHT (LBS.)				
			30°	45°	60°	90°	30°	45°	60°	90°	
13"	16"	24"	5T/12S	8T/12S	10T/12S	16T/4S	317	323	330	336	
15"	18"						300	336	343	349	
17"	20"						343	350	357	364	
19"	22"						357	364	371	378	
21"	24"						371	378	386	393	
23"	26"						386	393	401	408	
25"	28"						401	409	417	425	
27"	30"	32-1/2"	7T/12S	10T/12S	14T/12S	20T/4S	417	425	434	442	
31"	34"						529	540	551	562	
33"	36"						550	562	573	585	
37"	40"						589	601	613	625	
39"	42"						612	625	638	651	
			48"	10T/12S	14T/12S	22T/12S	30T/4S				

*T= Tapered, S- Straight

PLAN VIEW - 30°, 45°, 60° and 90° CURVES

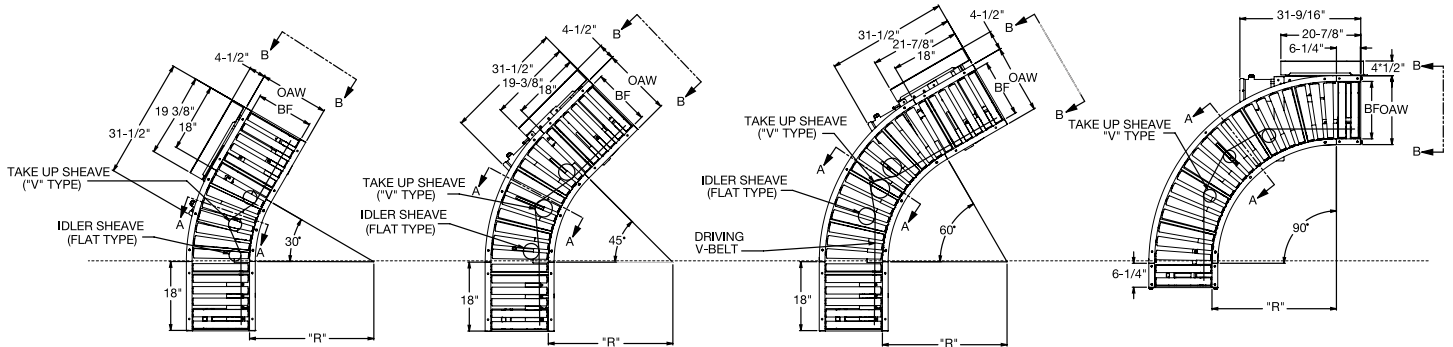

END/SIDE VIEW

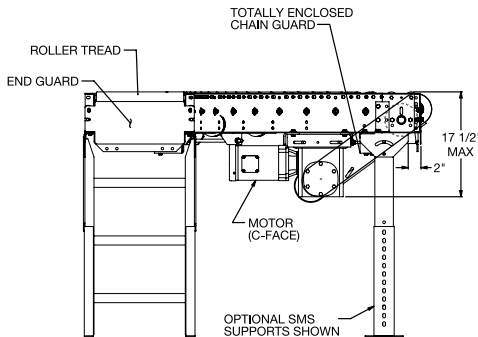

SECTION VIEW A-A

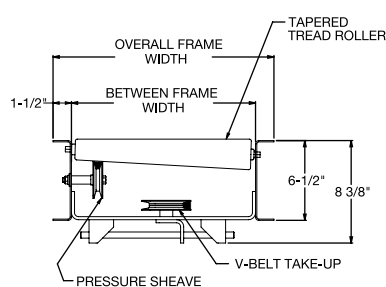

SECTION VIEW B-B

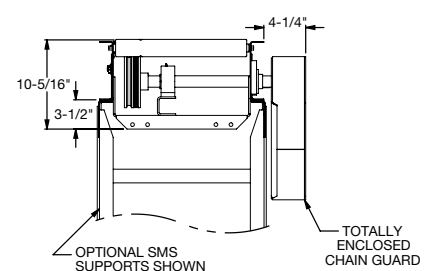

Note: Curves are non-accumulating

STANDARD SPECIFICATIONS

BED – 6 ½ in. deep x 1 ½ in. flange x 12 ga. powder coated steel channel with 2-1/2 in. dia. tapered to 1-11/16 in. dia. x 14 ga. galvanized rollers. 1.9 in. dia. x 16 ga. galvanized rollers provided in tangent sections.

CURVES: 30, 45, 60 and 90 degree curves. 24 in., 32 ½ in. or 48 in. radius dependent upon between frame widths.

COUPLINGS – Butt type for connecting to VBS19, VBCS19, VBSS19, BDS19T or BDS19M conveyors.

END DRIVE – Mounted underneath bed section on outside radius.

DRIVE BELT – Endless B-section V-Belt, industrial grade.

POSITIVE DRIVE PRESSURE SHEAVES – 2 1/2 in. dia. with 3/8 in. bore.

IDLER SHEAVE – 4 in. dia. x 5/8 in. bore V-type and/or 5 in. dia. 5/8 in. bore flat-type.

TAKE-UP SHEAVE – 4 3/8 in. dia. x 5/8 in. bore V-type sheave to maintain proper V-belt tension.

BEARINGS – Tread rollers have pre-lubricated ball bearings. Flange and pillow block bearings are sealed, pre-lubricated.

CONVEYING SPEED – Constant 65 FPM.

SPEED REDUCTION – Sealed worm gear speed reducer with No. 50 roller chain to drive shaft.

MOTOR – ½ HP – 230/460V-3 phase 60 Hz totally enclosed fan cooled, energy efficient.

CAPACITY – 500 lbs. total distributed live load.

Horsepower required to slave-drive V-belt curves from straight sections affects the maximum length of straight sections due to the capacity of the driving V-Belt. The four arrangements shown, illustrate basic slave limitations. Other arrangements are possible.

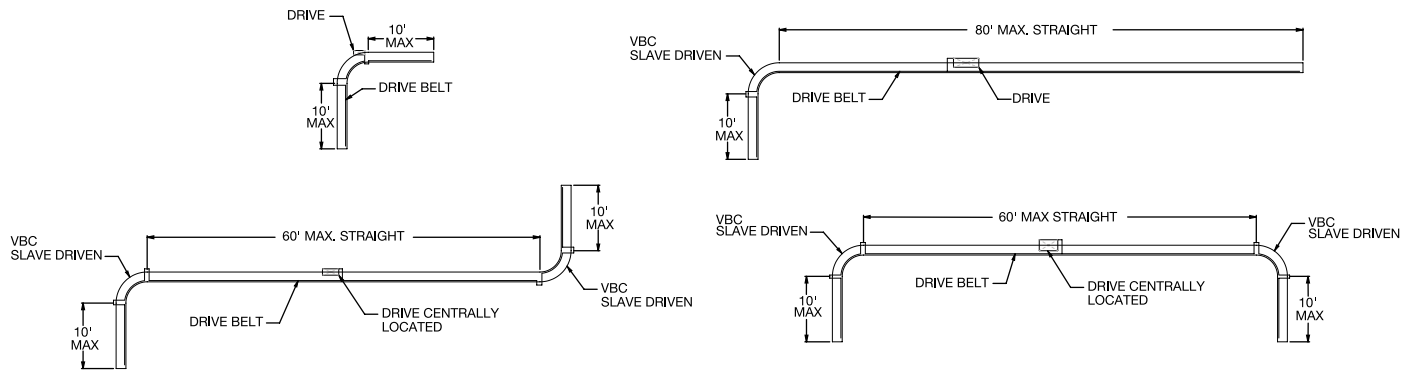

OPTIONAL EQUIPMENT

FLOOR SUPPORTS – SMS floor supports are available with a wide range of adjustments. Specify top of roller elevation. One support is required at every bed joint and at the ends of conveyor. Holes in feet are provided for lagging to floor. Knee braces supplied on SMS-7 support and above.

CONVEYING SPEED – Other constant and variable speeds. Note: Capacity affected with speed change.

- Underhung and side mounted drives: 25 – 120 FPM in any increment
- Shaft mounted drive: 25, 30, 45, 50, 65, 85 and 105 FPM nominal
- Consult factory for speeds not listed

END DRIVE – Mounted on inside radius. Minimum elevation 18-7/8 in.

SHAFT MOUNTED DRIVE – Drive unit mounted on extended drive shaft. Mounting bracket and torque arm allow for multiple mounting positions. Minimum elevation:

- Standard sheave retainer: 10 1/4 in TOR
- Low elevation sheave retainer: 8 3/4 in. TOR

SIDE MOUNTED DRIVE – Motor reducer unit mounted to side of conveyor. Minimum elevation:

- Standard sheave retainer: 10 1/4 in. TOR
- Low elevation sheave retainer: 9 1/2 in. TOR

GUIDE RAILS – Adjustable channel guide rails, fixed angle and channel guide rails. Note: If product comes in contact with guide rails, product flow will be affected.

OTHER ACCESSORIES – Poly-tier supports, ceiling hangars. See accessory section.

SLAVE DRIVEN – Omit standard drive and slave drive curve from VBS19, VBCS19, VBSS19, BDS19T, or BDS19M conveyors. Minimum elevation 11 in. (Provide sketch illustrating location of slave connection).

MOTORS – Inverter duty, premium energy efficient, single phase, brake motor, other characteristics. 1 HP maximum.

ELECTRICAL CONTROLS – One direction manual start switch, reversing drum switch, non-reversing and reversible IEC starters and push-button stations, AC variable frequency drive.