

# VBSS14

## V-BELT DRIVEN LIVE ROLLER STRAIGHT SPUR (1 3/8 in. dia. x 18 ga. rollers)

The Model VBSS14 straight spurs are used to transfer product from one conveying line onto another. Offering a positive drive for merging or diverging applications, they are available self-powered or can be slave driven from a straight section or curve.

- 4 Widths
- 30 and 45 degree straight spurs
- Right or Left Hand Units Available

BETWEEN FRAME WIDTH	OVERALL FRAME WIDTH	"A"		"B"		WEIGHT (LBS.)	
		30°	45°	30°	45°	30°	45°
10"	12"	32"	23"	30"	21"	187	162
13"	15"	38"	26"	36"	24"	193	167
16"	18"	44"	32"	42"	30"	200	172
22"	24"	56"	41"	54"	39"	206	177

PLAN VIEW - 30°, 45° STRAIGHT SPURS

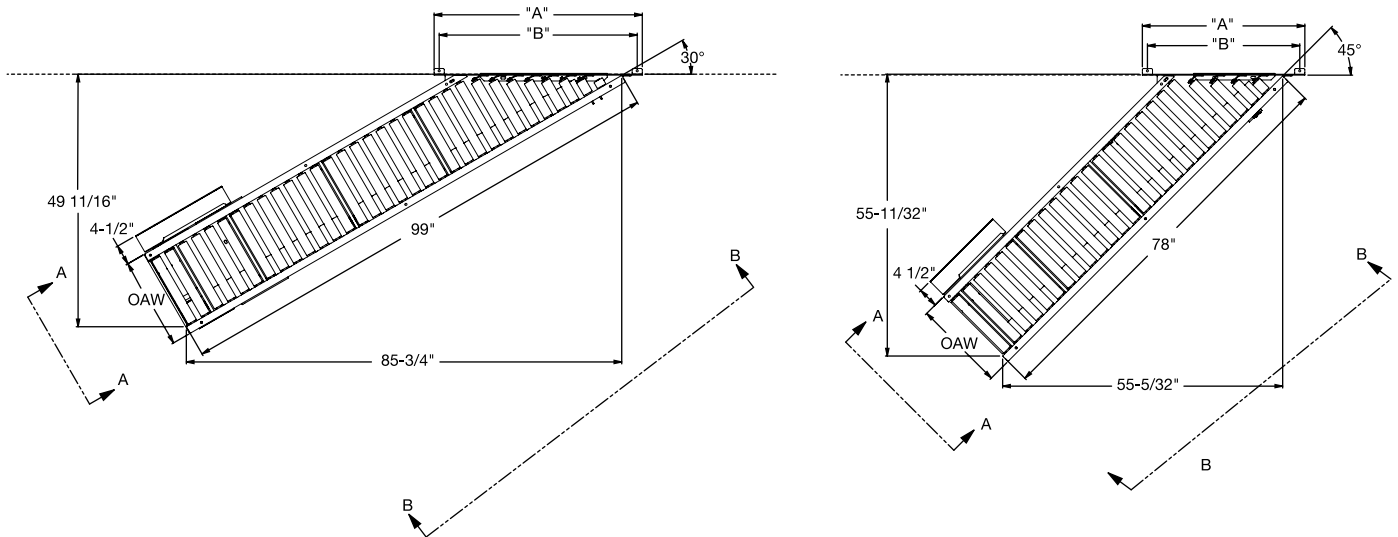

SECTION VIEW A-A

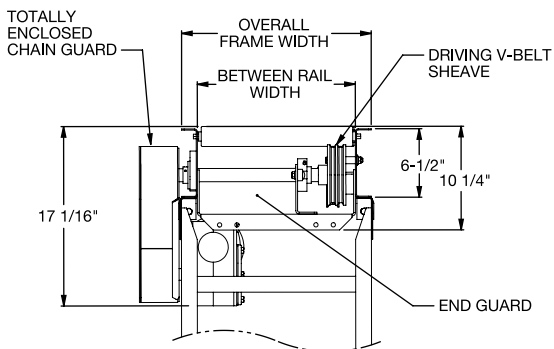

SIDE VIEW B-B

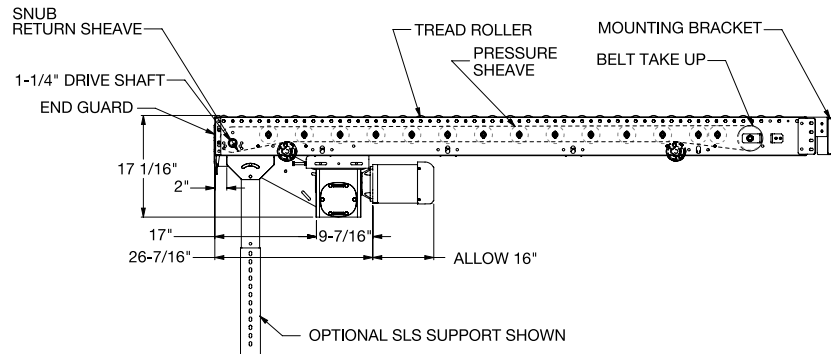

## STANDARD SPECIFICATIONS

**BED** – 6 1/2 in. deep x 1 in. flange x 12 ga. powder coated steel channel with 1 3/8 in. dia. x 18 ga. rollers.

**SPUR CURVES:** 30 and 45 degree straight spurs

**COUPLINGS** – Butt type for connecting to VBS14 or VBC14 conveyors

**END DRIVE** – Mounted underneath bed section of short rail.

**DRIVE BELT** – Endless B-section V-belt, industrial grade.

**PRESSURE SHEAVES** – 2 1/2 in. dia. with 3/8 in. bore.

**IDLER SHEAVE** – 4 in. dia. x 5/8 in. bore V-type and/or 5 1/2 in. dia. 5/8 in. bore flat-type.

**BEARINGS** – Tread rollers have pre-lubricated ball bearings. Flange and pillow block bearings are sealed and pre-lubricated.

**MOUNTING BRACKET** – Bracket is supplied to attach spur to side channel of VBS14 conveyors.

**CONVEYING SPEED** – Constant 65 FPM.

**SPEED REDUCTION** – Sealed worm gear speed reducer with No. 50 roller chain to drive shaft.

**MOTOR** – 1/2 HP –230/460V-3 phase 60Hz totally enclosed fan cooled, energy efficient

**CAPACITY** – 150 lbs. total distributed live load.

Live Roller Spurs are used to transfer product onto and off of main conveyor lines. The illustrations below show the correct usage of turning wheels with spurs in diverging and merging applications

### DIVERGING

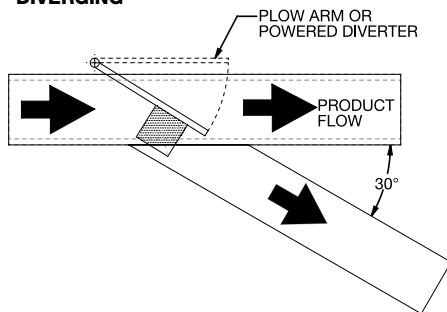

### MERGING

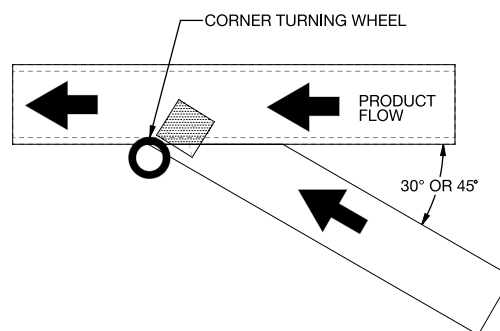

### SPUR FLOW (SPECIFY)

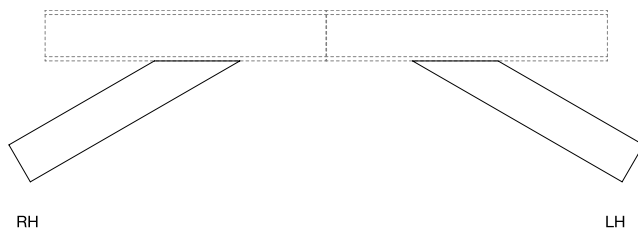

### MOUNTING BRACKET

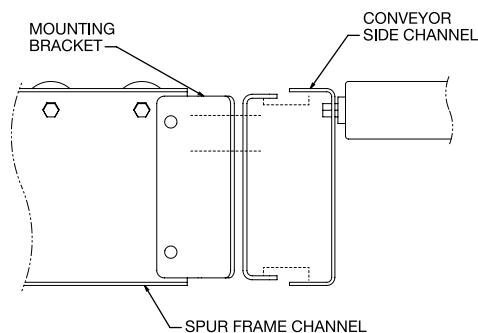

## OPTIONAL EQUIPMENT

**FLOOR SUPPORTS** – SLS Type floor supports are available with a wide range of adjustment. Specify top of roller elevation. One support required at every bed joint and ends of conveyor. Holes in feet for lagging to floor. Knee braces supplied on SLS-7 support and higher.

**CONVEYING SPEED** – Other constant and variable speeds.

Note: Capacity affected with speed change.

- Underhung and side mounted drives: 25 – 120 FPM in any increment
- Shaft mounted drive: 25, 30, 45, 50, 65, 85 and 105 FPM nominal
- Consult factory for speeds not listed

**MOTORS** – Inverter duty, premium energy efficient, single phase, brake motor, other characteristics. 1 HP maximum.

**END DRIVE** – Mounted underneath bed section of long rail. Minimum elevation 18-7/8 in.

**SHAFT MOUNTED DRIVE** – Drive unit mounted on extended drive shaft. Mounting bracket and torque arm allow for multiple mounting positions. Minimum elevation:

- Standard sheave retainer: 9 3/4 in TOR
- Low elevation sheave retainer: 8 1/4 in. TOR

**SIDE MOUNTED DRIVE** – Motor reducer unit mounted to side of conveyor. Minimum elevation:

- Standard sheave retainer: 10 1/4 in. TOR
- Low elevation sheave retainer: 9 1/2 in. TOR

**GUIDE RAILS** – Adjustable channel guide rails, fixed angle and channel guide rails. Note: If product comes in contact with guide rails, product flow will be affected

**OTHER ACCESSORIES** - Poly-tier supports, ceiling hangars. See accessory section

**SLAVE DRIVEN** – Standard drive may be omitted and curve slave driven from VBS14 or VBC14. (Specify by sketch, location of slave connection. Minimum elevation 11 in.

**ELECTRICAL CONTROLS** – Non-reversing or reversible magnetic starters and push-button stations. AC variable frequency drive.